

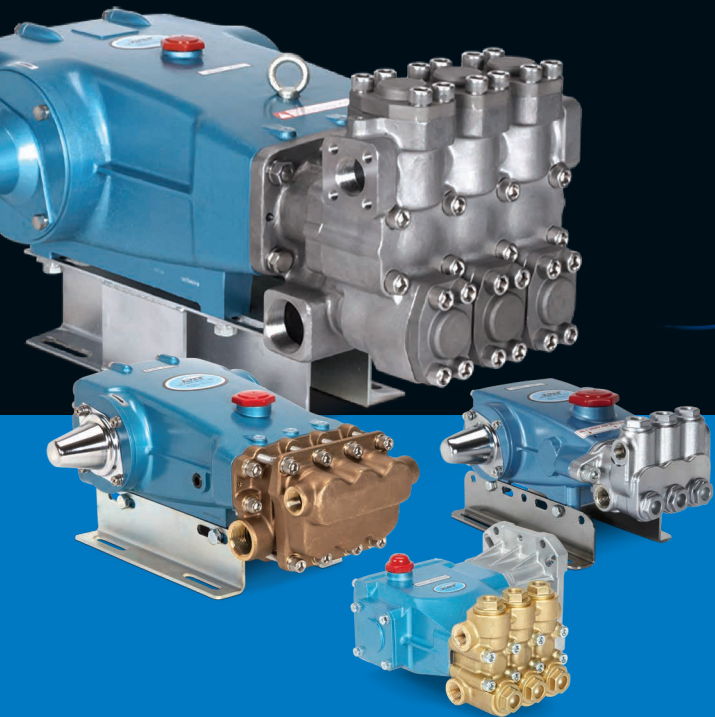

**PIJTERSEN**

E-mail : [info@pijtersen.nl](mailto:info@pijtersen.nl) / [info@catpumps.nl](mailto:info@catpumps.nl)  
Internet: [www.pijtersen.nl](http://www.pijtersen.nl) / [www.catpumps.nl](http://www.catpumps.nl)

# Pump Catalog

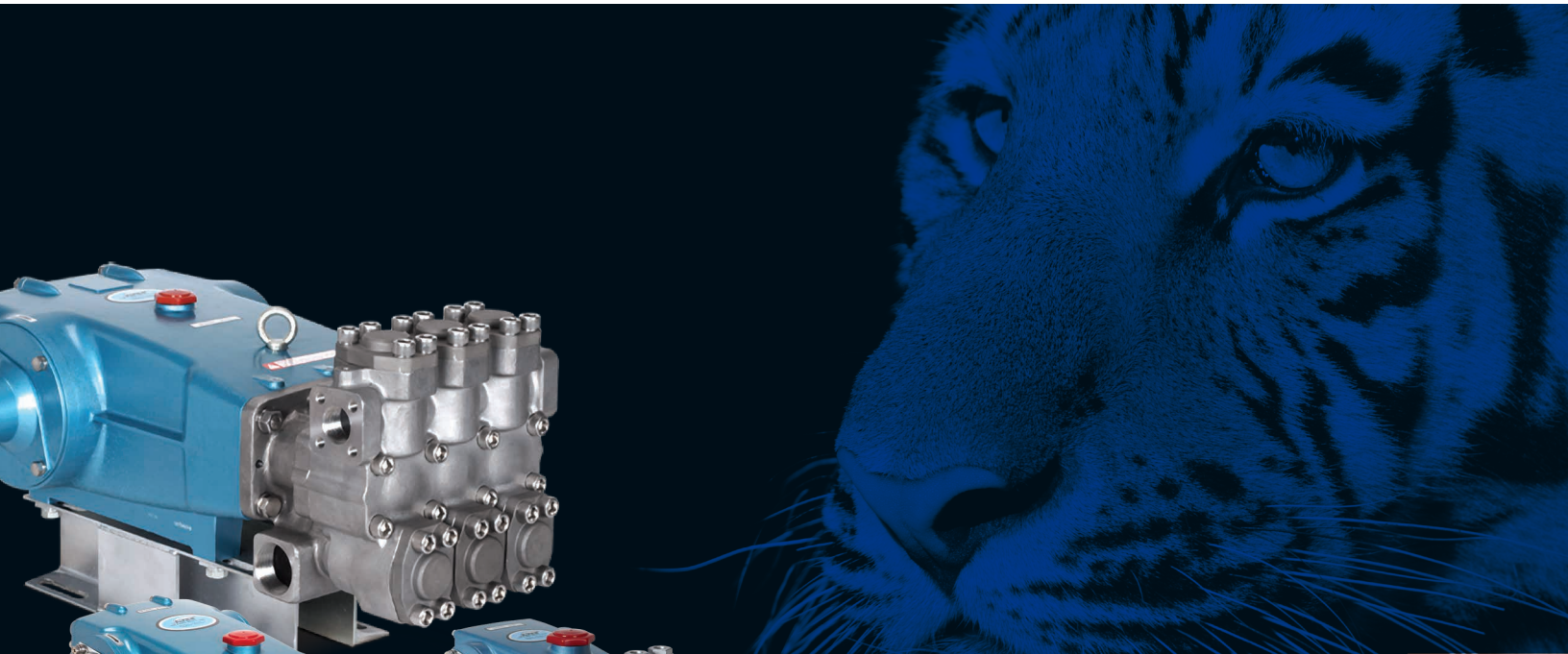

Product Quality, Reliability and Support You Expect

# World Leader in Triplex Reciprocating High-Pressure Pumps

Cat Pumps designs and builds products to the highest quality level for one major reason: our customers depend on our products to keep their equipment running. Every design detail is optimized for long product life and reliable performance.

Cat Pumps embraces a zero defect manufacturing philosophy. Stringent process controls result in highly repeatable processes, yielding the highest level of product reliability. Cat Pumps commitment to quality is legendary within the industry, earning the trust from customers worldwide. When it needs to run, make it Cat Pumps.

## Product Performance Range

A wide range of pump options are available, including a variety of products that meet various industry certifications and directives.

- Flow: 0.13 to 240 gpm (0.49 to 908 lpm)
- Pressure: 100 to 10,000 psi (6.9 to 689 bar)
- RPM: 100 to 3450
- Liquid Temperature: -10° to 240°F (-23° to 115°C)
- Manifold Materials: Brass, Nickel Aluminum Bronze, 304 and 316 Stainless Steel, Duplex Stainless Steel
- Drives: Electric, Engine, Hydraulic, Pneumatic

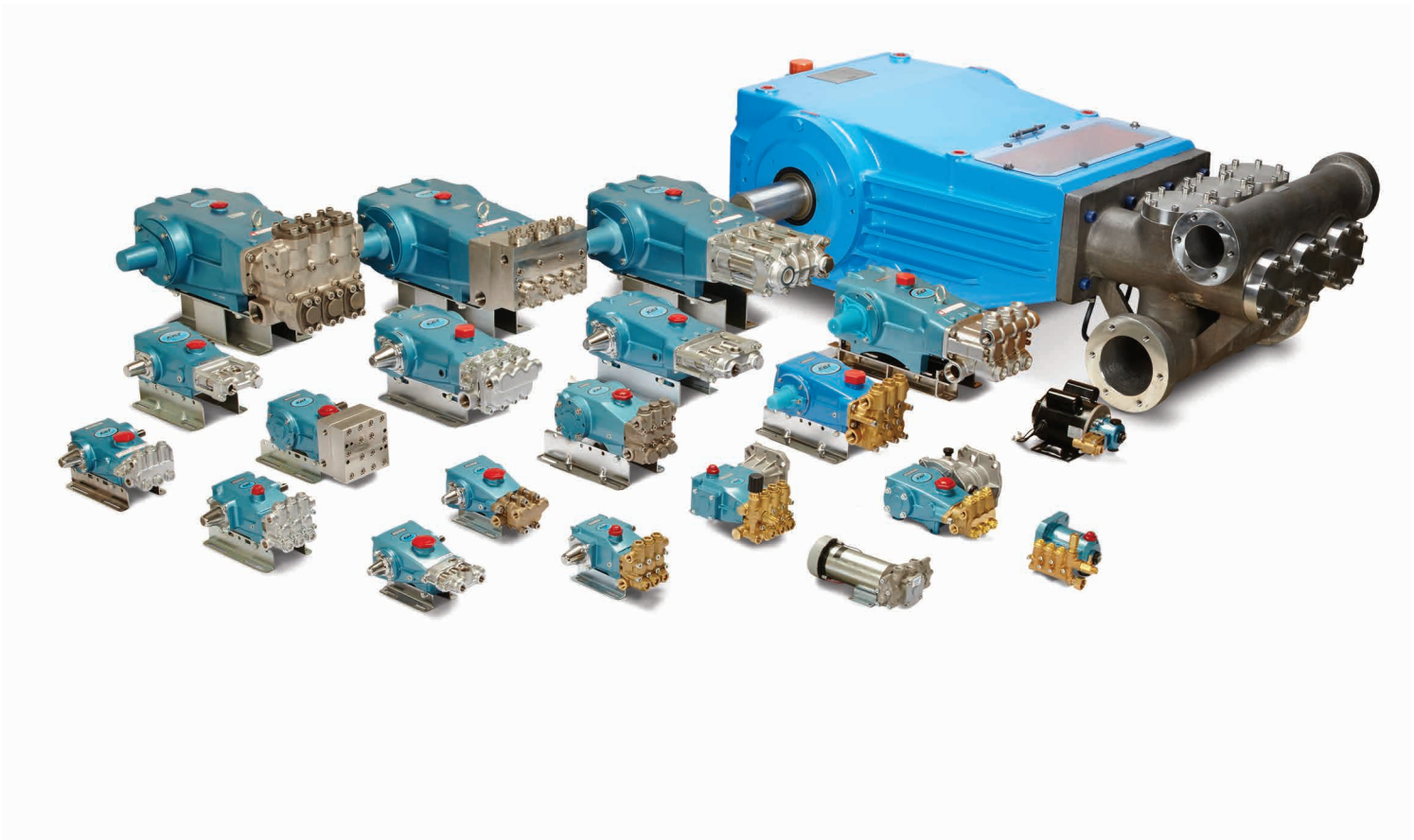

# Product Ordering

## Using This Catalog

The pump sections of this catalog are organized by drive type/flow rate/manifold materials (brass, 316 stainless steel, duplex stainless steel and nickel aluminum bronze). The model numbers listed represent standard pumps equipped with Buna-N seals and O-rings, except for specialty pumps, such as CO<sub>2</sub>, TEG and portable extractors, which are fitted with unique seals for the application.

Standard Buna-N pump seals and/or O-rings can be changed by adding a suffix to the standard model number that represents the desired new seal material.

### Optional Seal and O-Ring Configurations

MATERIAL CODE	DESCRIPTION	MAX. TEMPERATURE *	PUMP MODEL SUFFIX
NBR	Medium Nitrile (Buna-N) seals and O-Rings	160°F (71°C)	—
FPM	Fluorocarbon (Viton®) seals and O-Rings, chemical resistance	180°F (82°C)	.0110
EPDM	Ethylene Propylene Diene Monomer seals and O-Rings	160°F (71°C)	.0220
HT	High-temperature high pressure seals	180°F (88°C)	.3000
STHT	High-temperature high pressure seals, special Teflon® low-pressure seals, NBR O-Rings	190°F (88°C)	.3400
	High-temperature high pressure seals, special Teflon® low-pressure seals, FPM O-Rings	190°F (88°C)	.3410
PTFE	Pure Polytetrafluoroethylene (Teflon®) Seals and Buna-N O-Rings	190°F (88°C)	.0700
	Pure Polytetrafluoroethylene (Teflon®) Seals and FPM O-Rings	200°F (93°C)	.0710
IPFE	I-Perfluoroelastomer (Teflon®) Seals and Isolast O-Rings	200°F (93°C)	.0770
ST4	Special blend PTFE high and low pressure seals, Buna-N O-Rings	190°F (88°C)	.4400
	Special blend PTFE high and low pressure seals, FPM O-Rings	200°F (93°C)	.4410
NBRS	Buna-N silicone free seals and O-Rings	160°F (71°C)	.6000

FPM = Fluorocarbon, EPDM = Ethylene Propylene Diene Monomer, HT = High Temp (EPDM Alternative), STHT = Special PTFE High Temperature

PTFE = Pure Polytetrafluoroethylene, IPFE = I-Perfluoroelastomer, ST4 = Special PTFE 4, NBR = Medium Nitrile (Buna-N), NBRS = Buna-N silicon free seals and O-Rings

\* See individual data sheet for each pump to verify actual maximum temperature allowed.

Viton® and Teflon® are registered trademarks of DuPont Dow Elastomers.

## Example

**Pump model 3535 can be changed from Buna-N to FPM. To convert pump model 3535 from Buna-N seals and O-rings to FPM (Viton®), add the suffix (.0110) to the standard pump model number (3535.0110). Use this new number when ordering the pump.**

Cat Pumps configures a number of pumps for special applications and certifications such as ATEX, CO<sub>2</sub>, TEG, Flushed, High-Temp and others. Please contact Cat Pumps directly at (763) 780-5440 for more information.

## Table of Contents

<b>Direct Drive Plunger Pumps</b>	Page 6	<b>Piston Pumps</b>	Page 14
Hollow Shaft: Brass Manifold	6	<b>Specialty Pumps</b>	15
Hollow Shaft: 316 Stainless Steel	7	Flushed Manifold Pumps	15
Gearbox: Brass Manifold	7	High Temperature Pumps	16
Gearbox: 316 Stainless Steel Manifold	7	Triethylene Glycol (TEG) Pumps, 240° F	16
Bell Housing: Brass Manifold	8	Washout Resistant Pumps	17
Bell Housing: 316 Stainless Steel Manifold	8	Liquid CO <sub>2</sub> Pumps	17
Bell Housing: Nickel Aluminum Bronze Manifold	8	Demand Genuine Cat Pumps Accessories	17
Direct-Drive Mounting Components	9	ATEX Pumps	18
<b>Belt Drive Plunger Pumps</b>		1CX Series Compact Misting Pumps	18
Brass and 304 Stainless Steel	10 – 11	1XP Series Portable Extractor Pumps	19
316 Stainless Steel	12	<b>Centrifugal Pumps</b>	20 – 21
Duplex Stainless Steel	13	<b>Custom Pumping Systems</b>	22 – 23
Nickel Aluminum Bronze	13		

# Pump Selection

## Plunger Pumps (0.13 – 240 gpm, 100 – 10,000 psi)

Plunger pumps utilize spring-loaded closed and hydraulically opened inlet and discharge valves to direct flow through the pump manifold. At the beginning of the stroke, the plunger displaces the liquid in the manifold chamber, forcing the discharge valve open. When the plunger reaches the end of the stroke, the discharge valve closes. As the plunger rod begins its backward stroke, the inlet valve opens to allow more liquid into the manifold chamber, thereby keeping a smooth forward flow of liquid.

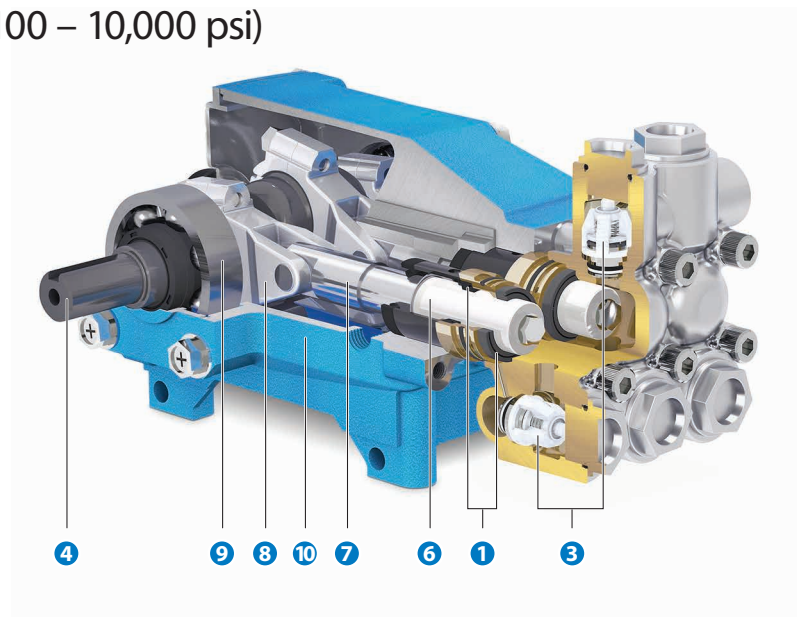

## XP Series Pumps (0.5 – 2 gpm, 100 – 1,000 psi)

In XP series pumps, fluid enters the inlet port and flows through the drive-end, lubricating the connecting rods and plunger rods as it passes to the inlet valves. Both inlet and discharge valves are spring-loaded closed and hydraulically opened, similar to plunger pumps, however, they utilize a flow-through ceramic plunger design. The continuous forward flow characteristics in conjunction with the packing design of plunger pumps result in improved suction capabilities as well as extended seal life.

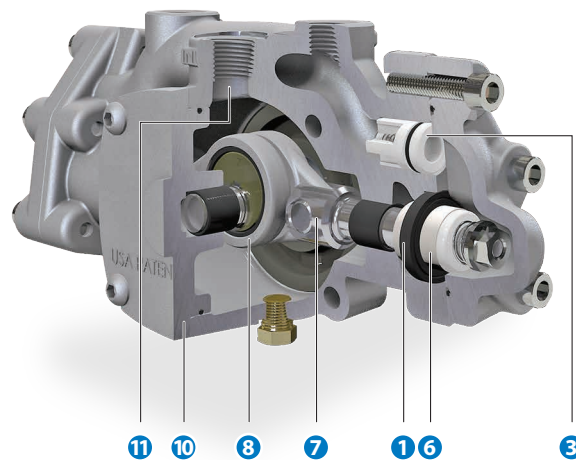

## Features

- 1 Specially formulated, Cat Pumps exclusive high pressure and low pressure seals offer unmatched performance and seal life.
- 2 100% wet cup/seal design adds to service life by allowing pumped fluids to cool and lubricate the elastomers on both sides.
- 3 Stainless steel valves, seats, and springs provide corrosion-resistance, positive seating and long life.
- 4 Chrome-moly crankshaft provides unmatched strength and surface hardness for long life.
- 5 The patented stepped piston rod with hard chrome-plated sleeve provides a durable wear surface and easy wet end servicing.
- 6 Precision-polished, solid ceramic plungers provide maximum resistance to corrosion and abrasion, extending seal life.



## Piston Pumps (3.0 – 60 gpm, 100 – 1,500 psi)

The design of the piston pump is for the fluid to move continually in one, smooth forward direction. This design allows greater suction capabilities and reduces the risk of cavitation provided the pump is properly primed. At the beginning of the stroke, the mechanically actuated inlet valve (and piston) will close. As the piston rod moves forward, the liquid is forced out through the discharge valves. Simultaneously, the liquid enters the pump inlet and flows in behind the inlet valve. As the piston rod begins the backward stroke, the inlet valve mechanically opens, permitting the liquid to continue its flow forward through the piston into the discharge chamber.

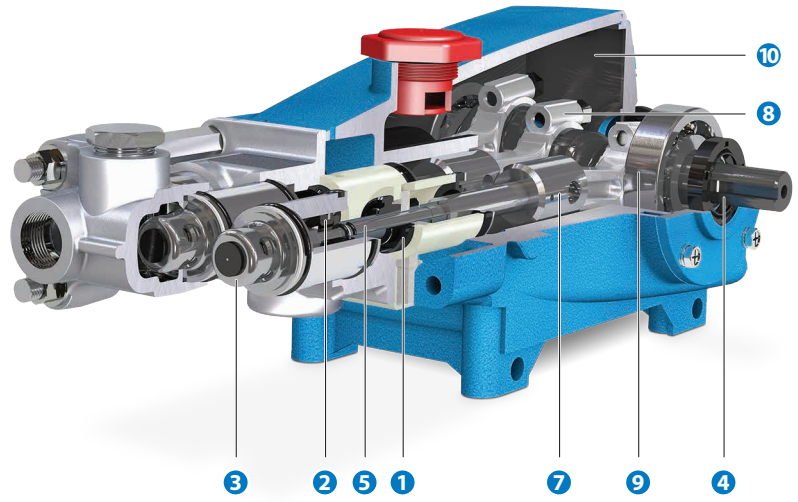

## SF Series Pumps (0.5 – 5.0 gpm, 100 – 3,500 psi)

In SF series pumps, both the inlet and discharge valves are spring-loaded closed and hydraulically opened, similar to plunger pumps, however, they have a flow-through ceramic plunger design. The continuous forward flow characteristic of piston pumps is utilized in conjunction with the packing design of the plunger pumps. These features give SF pumps both strong suction capabilities and higher pressure performances.

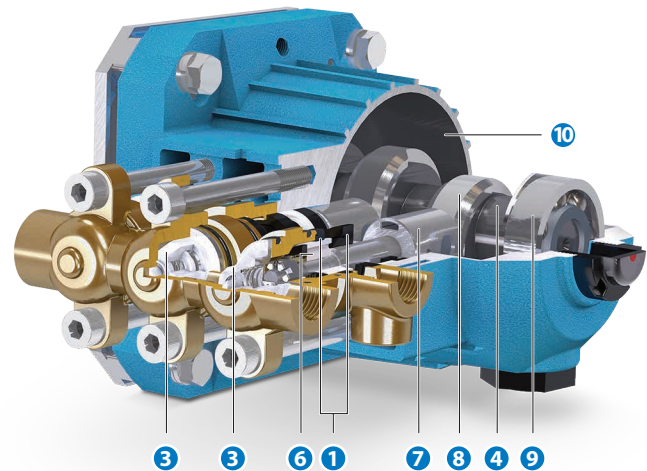

- 7 The high strength stainless steel plunger rods have a 360° supported crosshead providing uncompromising plunger rod alignment.
- 8 Matched oversized connecting rods are made of high strength material with exceptional bearing quality.
- 9 Oversized ball bearings or tapered roller bearings provide extended bearing life.

- 10 High Strength, light weight die cast aluminum crankcase with splash oil design allows operation at speeds as low as 100 RPM.
- 11 Patented greaseless design uses water from inlet as lubrication, eliminating the maintenance and mess of grease or oil.

# Plunger Pumps



Model 4DX10ER

## DIRECT DRIVE, HOLLOW SHAFT, BRASS MANIFOLD

Electric Motor, 5/8" and 3/4", 56C Face

PUMP MODEL	MAXIMUM FLOW		MAXIMUM PRESSURE		RPM	SHAFT
	GPM	LPM	PSI	BAR		
4DX03ELR	0.3	1.1	2000	138	1725	5/8"
4DX10ER	1.0	3.8	2000	138	3450	5/8"
4DX15ER	1.5	5.7	2000	138	3450	5/8"
4DX20ER	2.0	7.6	2000	138	3450	5/8"
4SP21ELR	2.1	7.9	2000	138	1750	5/8"
4DX27ER	2.7	10.3	2000	138	3450	5/8"
4SP29ELR	2.85	10.8	1200	83	1725	5/8"
4DX30ER	3.0	11.4	2000	138	3450	5/8"
2SF30GES	3.0	11.4	2000	138	3450	3/4"
2SF35ES	3.5	13.3	1500	103	3450	5/8"
2SF35GES	3.5	13.3	2000	138	3450	3/4"
2SFP500EL	5.0	19.0	500	34.5	1750	5/8"

Note: Pumps rated at 3450 rpm can operate at 1725 rpm, reducing flow by 50%.

$$\text{Electric Brake Hp} = \frac{\text{gpm} \times \text{psi}}{1460}$$

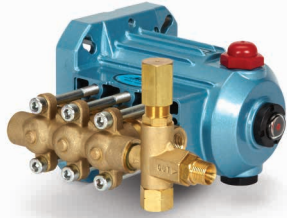

Model 2SF22ES

## DIRECT DRIVE, HOLLOW SHAFT, BRASS MANIFOLD

Electric Motor, 1 1/8", 184TC Face

PUMP MODEL	MAXIMUM FLOW		MAXIMUM PRESSURE		RPM	SHAFT
	GPM	LPM	PSI	BAR		
5SP30ELR	3.0	11.4	3000	207	1750	1 1/8"
5SP35ELR	3.5	13.3	2500	172	1750	1 1/8"
5SP40ELR	4.0	15.2	2000	138	1750	1 1/8"

$$\text{Electric Brake Hp} = \frac{\text{gpm} \times \text{psi}}{1460}$$



Model 5SP35ELR

## DIRECT DRIVE, HOLLOW SHAFT, BRASS MANIFOLD

Engine, 3/4"

PUMP MODEL	MAXIMUM FLOW		MAXIMUM PRESSURE		RPM	SHAFT	HP Typical Gas Engine*
	GPM	LPM	PSI	BAR			
4DNX25GSI	2.5	9.5	3000	207	3450	3/4"	6.5
4DNX27GSI	2.7	10.3	3000	207	3450	3/4"	8
4DX29GUIF	2.9	11.0	2600	179	3450	3/4"	6.5
2SF35GS	3.5	13.3	2000	138	3450	3/4"	8

\*Consult engine manufacturer for actual torque available at required speed.



Model 66DX40G1I

## DIRECT DRIVE, HOLLOW SHAFT, BRASS MANIFOLD

Engine, 1"

PUMP MODEL	MAXIMUM FLOW		MAXIMUM PRESSURE		RPM	SHAFT	HP Typical Gas Engine*
	GPM	LPM	PSI	BAR			
66DX30G1I	3.0	11.4	4000	276	3450	1"	13
4SPX32G1I	3.2	12.2	3000	207	3450	1"	9
66DX35G1I	3.5	13.3	4000	276	3450	1"	13
66DX40G1I	4.0	15.2	4000	276	3450	1"	16
66DX50G1I	5.0	19.0	3500	241	3400	1"	13

\*Consult engine manufacturer for actual torque available at required speed.

# Plunger Pumps

## DIRECT DRIVE, HOLLOW SHAFT, 316 STAINLESS STEEL MANIFOLD

Electric Motor, 3/8", 56C Face

PUMP MODEL	MAXIMUM FLOW		MAXIMUM PRESSURE		RPM	SHAFT
	GPM	LPM	PSI	BAR		
2SF05SEEL	0.5	1.9	1200	83	1725	5/8"
2SF10SEEL	1.0	3.8	1200	83	1725	5/8"
2SF15SEEL	1.5	5.7	1200	83	1725	5/8"
2SF22SEEL	2.2	8.4	1200	83	1725	5/8"
2SFQ25SEEL	2.5	9.5	1200	83	1725	5/8"
2SFQ29SEEL	2.85	10.8	1200	83	1725	5/8"
2SFQ35SEEL	3.5	13.3	1200	83	1725	5/8"
2SFQ42SEEL	4.2	15.9	1000	69	1725	5/8"

$$\text{Electric Brake Hp} = \frac{\text{gpm} \times \text{psi}}{1460}$$



Model 2SF22SEEL

## DIRECT DRIVE, HOLLOW SHAFT GEARBOX, BRASS MANIFOLD

Engine, 3/4" and 1"

PUMP MODEL	MAXIMUM FLOW		MAXIMUM PRESSURE		RPM ENGINE	SHAFT	HP Typical Gas Engine*
	GPM	LPM	PSI	BAR			
740G1	2.8	10.6	5000	345	3465	1"	13
3CP1120G	3.5	13.3	2200	152	3600	3/4"	8
760G1	3.5	13.3	5000	345	3465	1"	16
5CP3160CSSG1	4.0	15.2	3500	241	3320	1"	13
5CP3120CSSG1	4.5	17.0	3500	241	3353	1"	16
60G1	4.5	17.0	4000	276	3450	1"	18
700G1	4.5	17.0	5000	345	3465	1"	20
5CP3150CSSG1	5.0	19.0	3000	207	3450	1"	13
5CP5135CSSG1	5.8	21.9	3500	241	3450	1"	13
5CP5140CSSG1	6.2	23.4	3000	207	3450	1"	18
5CP6120CSSG1	7.2	27.2	1500	103	3450	1"	8
5CP6180CSSG1	8.0	30.4	1500	103	3450	1"	11
56G1	8.0	30.4	2500	172	3600	1"	16
56HSG1	8.0	30.4	3000	207	3600	1"	22
5CP6190G1	9.7	36.7	1200	83	3450	1"	11
7CP6110CSG1	10.0	38.0	2000	138	3400	1"	18
7CP6160CSG1	10.0	38.0	2500	172	3400	1"	22
7CP6170G1	12.0	45.4	1800	124	3264	1"	16

Note: All 1" Gearboxes are also available in 1 1/8" size (G118)

\*Consult engine manufacturer for actual torque available at required speed.



Model 56G1



Model 5CP3120CSSG1

## DIRECT DRIVE, HOLLOW SHAFT GEARBOX, 316 STAINLESS STEEL MANIFOLD

Engine, 3/4" and 1"

PUMP MODEL	MAXIMUM FLOW		MAXIMUM PRESSURE		RPM ENGINE	SHAFT	HP Typical Gas Engine*
	GPM	LPM	PSI	BAR			
3CP1241G	3.0	11.4	2000	138	3600	3/4"	5
3CP1211G	3.8	14.4	1500	103	3400	3/4"	5
5CPQ6241CSG1	4.0	15.2	2000	138	3600	1"	8
781G1	4.5	17.0	5000	345	3465	1"	20
5CPQ6251G1	5.0	19.0	2000	138	3600	1"	9
5CPQ6221G1	7.4	28.0	1200	83	3600	1"	8
7CP6111CSG1	10.0	38.0	2000	138	3400	1"	18

Note: All 1" Gearboxes are also available in 1 1/8" size. (G118). \*Consult engine manufacturer for actual torque available at required speed.



Model 7CP6111CSG1

# Plunger Pumps

## DIRECT DRIVE, SOLID SHAFT, BRASS MANIFOLD Electric Motor - Bell Housing

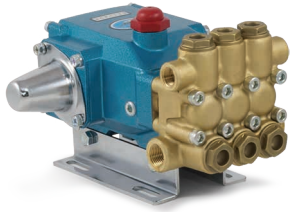

Model 3CP1120

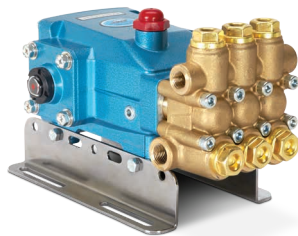

Model 5CP3160CSS

PUMP MODEL	MAXIMUM FLOW		MAXIMUM PRESSURE		RPM	SHAFT
	GPM	LPM	PSI	BAR		
5CP4110CSS	2.2	8.4	4000	276	1750	20 mm
3CP1130	2.4	9.1	2200	138	1725	16.5 mm
5CP3105CSS	2.5	9.5	3500	241	1750	20 mm
5CP4112CSS	2.7	10.3	4000	276	1750	20 mm
740	2.9	11.0	5000	345	1750	24 mm
5CP4114CSS	3.2	12.1	4000	276	1750	20 mm
3CP1140	3.6	13.7	2200	152	1725	16.5 mm
5CP3110CSS	3.6	13.7	3500	241	1750	20 mm
760	3.6	13.6	5000	345	1750	24 MM
5CP4116CSS	3.8	14.4	4000	276	1750	20 mm
5CP2140WCS	4.0	15.2	2500	172	1725	20 mm
3CP1120	4.2	16.0	2200	152	1725	16.5 mm
5CP4118CSS	4.2	16.0	4000	276	1750	20 mm
5CP3160CSS	4.3	16.3	3500	241	1750	20 mm
5CP4120CSS	4.5	17.0	4000	276	1750	20 mm
60	4.7	17.9	4000	276	1750	24 mm
700	4.7	17.9	5000	345	1750	24 mm
5CP3120CSS	4.8	18.2	3000	207	1750	20 mm
5CP2150W	5.0	19.0	2000	138	1725	20 mm
5CP3150CSS	5.2	19.8	3000	207	1750	20 mm
5CP5120	6.0	22.8	2500	172	1750	20 mm
5CP5135CSS	6.0	22.8	3500	241	1750	20 mm
5CP5140CSS	6.4	24.3	3000	207	1750	20 mm
5CP6120	7.4	28.1	1200	83	1725	20 mm
56	8.0	30.4	2500	172	1760	24 mm
56HS	8.0	30.4	3000	207	1760	24 mm
5CP6180CSS	8.2	31.0	1500	103	1750	20 MM
5CP6190	10.0	38.0	1200	83	1750	20 mm
7CP6110CS	10.5	39.9	2000	138	1750	24 mm
7CP6160CS	10.6	40.1	2500	172	1750	24 mm

$$\text{Electric Brake Hp} = \frac{\text{gpm} \times \text{psi}}{1460}$$

## DIRECT DRIVE, SOLID SHAFT, 316 STAINLESS STEEL MANIFOLD Electric Motor - Bell Housing



Model 3CP1231

PUMP MODEL	MAXIMUM FLOW		MAXIMUM PRESSURE		RPM	SHAFT
	GPM	LPM	PSI	BAR		
3CP1231	2.3	8.7	2000	138	1725	16.5 mm
784	2.9	11.0	5000	345	1750	24 mm
3CP1241	3.6	13.7	2000	138	1725	16.5 mm
786	3.6	13.7	5000	345	1750	24 mm
5CPQ6241CS	4.0	15.2	2000	138	1725	20 mm
3CP1221	4.2	16.0	2000	138	1725	16.5 mm
781	4.7	17.8	5000	345	1750	24 mm
3CP1211CS	5.0	19.0	1700	117	1750	16.5 mm
5CPQ6251	5.0	19.0	2000	138	1725	20 mm
5CPQ6261CSS	5.5	20.9	2000	138	1725	20 mm
5CPQ6271CSS	6.6	25.1	1800	124	1725	20 mm
5CPQ6221	7.4	28.0	1200	83	1725	20 mm
7CP6111CS	10.5	39.9	2000	138	1750	24 mm

## DIRECT DRIVE, SOLID SHAFT, NICKEL ALUMINUM BRONZE MANIFOLD Electric Motor - Bell Housing



Model 277

PUMP MODEL	MAXIMUM FLOW		MAXIMUM PRESSURE		RPM	SHAFT
	GPM	LPM	PSI	BAR		
237	2.3	8.7	1500	103	1725	16.5 mm
247	3.6	13.7	1200	83	1725	16.5 mm
277	4.2	16.0	1000	69	1725	16.5 mm
347	4.0	15.2	1800	124	1725	20 mm
357	5.0	19.0	1500	103	1725	20 mm

$$\text{Electric Brake Hp} = \frac{\text{gpm} \times \text{psi}}{1460}$$



# Plunger Pumps

## Direct-Drive Mounting Components

### BELL HOUSING ASSEMBLY, NEMA AND SAE

PUMP SERIES	MODELS	ELECTRIC MOTOR		HYDRAULIC MOTOR	
		MOTOR FRAME	BELL HOUSING ASSY	SAE TYPE*	BELL HOUSING ASSEMBLY
3CP Series	All 3CP Models	56C - 145TC	76056.3CP	A2	76SAEA2.3CP
		182/184TC	76184.3CP	B2	76SAEB2.3CP
		213/215TC	76215.3CP	B4	76SAEB4.3CP
3FR Series	230 - 270, 231, 241, 271, 237, 247	56C - 145TC	76056.3FR	A2	76SAEA2.3FR
		182/184TC	76184.3FR	B2	76SAEB2.3FR
		213/215TC	76215.3FR	B4	76SAEB4.3FR
5CP Series	All 5CP Models	56C - 145TC	76056.5CP	A2	76SAEA2.5CP
		182/184TC	76184.5CP	B2	76SAEB2.5CP
		213/215TC	76215.5CP	B4	76SAEB4.5CP
		254/256TC	76256.5CP		
5FR Series	340, 350, 341, 351, 347, 357	56C - 145TC	76056.5FR	A2	76SAEA2.5FR
		182/184TC	76184.5FR	B2	76SAEB2.5FR
		213/215TC	76215.5FR	B4	76SAEB4.5FR
7CP Series	All 7CP Models	182/184TC	76184.7CP	A2	76SAEA2.7CP
		213/215TC	76215.7CP	B2	76SAEB2.7CP
		254/256TC	76256.7CP	B4	76SAEB4.7CP
7FR/8FR Series	56-60, 700-760, 781-786	182/184TC	76184.7FR	A2	76SAEA2.7FR
		213/215TC	76215.7FR	B2	76SAEB2.7FR
		254/256TC	76256.7FR	B4	76SAEB4.7FR
15FR Series	All 15FR Models	213/215TC	76215.15FR	B2	76SAEB2.15FR
		254/256TC	76256.15FR	B4	76SAEB4.15FR
		284/286TC	76286.15FR		
35FR Series	All 35FR Models			C2/C4	76SAEC.35FR

Bell housing assemblies include mounting hardware and flange

\*SAE Type: A2 = SAE "A" 2 Bolt, 3.25" Pilot, B2 = SAE "B" 2 Bolt, 4" Pilot, B4 = SAE "B" 4 Bolt, 4" Pilot, C2 = SAE "C" 2 Bolt, 5" Pilot, C4 = SAE "C" 4 Bolt, 5" Pilot

IEC Bell housing available upon request.



Bell Housing Series (Electric)



Bell Housing Assembly (Hydraulic)

### FLEXIBLE COUPLER ASSEMBLY, NEMA AND SAE

PUMP SERIES	MOTOR FRAME	FLEX COUPLER ASSY	TORQUE RATING	SAE TYPE*	FLEX COUPLER ASSY	SHAFT TO SHAFT	TORQUE RATING
3CP & 3FR	56C	8215	27 ft/lbs	A2	8271	16.5 mm x 5/8"	115 ft/lbs
	145TC	8210	27 ft/lbs	B2	8272	16.5 mm x 7/8"	115 ft/lbs
	182/184TC	8220	27 ft/lbs	B4	8272	16.5 mm x 7/8"	115 ft/lbs
	182/184TC	8225	174 ft/lbs				
	213/215TC	8270	92 ft/lbs				
5CP & 5FR	56C	8261	74 ft/lbs	A2	8273	20 mm x 5/8"	115 ft/lbs
	145TC	8260	74 ft/lbs	B2	8274	20 mm x 7/8"	115 ft/lbs
	182/184TC	8230	74 ft/lbs	B4	8274	20 mm x 7/8"	115 ft/lbs
	213/215TC	8275	92 ft/lbs				
	254/256TC	8217	150 ft/lbs				
7CP & 7FR	56C	8218	74 ft/lbs				
	182/184TC	8370	74 ft/lbs	A2	8371	24 mm x 5/8"	145 ft/lbs
	213/215TC	8375	74 ft/lbs	B2	8372	24 mm x 7/8"	145 ft/lbs
	254/256TC	8380	150 ft/lbs	B4	8372	24 mm x 7/8"	145 ft/lbs
15FR	213/215TC	8388	150 ft/lbs	B2/B4	8387	30mm x 7/8"	92 ft/lbs
	254/256TC	8382	150 ft/lbs				
	284/286TC	8383	225 ft/lbs				
35FR				C2/C4	997872	35mm x 1 1/4"	350 ft/lbs
				C2/C4	999368	35mm x 1 3/8"	350 ft/lbs
				C2/C4	994403	35mm x 1 1/2"	350 ft/lbs
				C2/C4	999180	35mm x 1 5/8"	350 ft/lbs
				C2/C4	999206	35mm x 1 7/8"	350 ft/lbs

\*SAE Type: A2 = SAE "A" 2 Bolt, 3.25" Pilot, B2 = SAE "B" 2 Bolt, 4" Pilot, B4 = SAE "B" 4 Bolt, 4" Pilot, C2 = SAE "C" 2 Bolt, 5" Pilot, C4 = SAE "C" 4 Bolt, 5" Pilot

IEC Flexible Coupler Assembly available upon request.



Flex Coupler Series

# Plunger Pumps

## SOLID SHAFT, BRASS MANIFOLD



Model 1810



Model 310

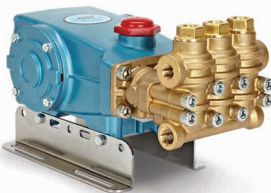

Model 700



Model 5CP2120W

PUMP MODEL	MAXIMUM FLOW		MAXIMUM PRESSURE		RPM	SHAFT
	GPM	LPM	PSI	BAR		
5CP4110CSS	2.2	8.4	4000	276	1750	20 mm
3CP1130	2.4	9.1	2200	138	1725	16.5 mm
5CP3105CSS	2.5	9.5	3500	241	1750	20 mm
5CP4112CSS	2.7	10.3	4000	276	1750	20 mm
740	2.9	11.0	5000	345	1750	24 mm
1810**	3.0	11.4	10000	689	1500	30 mm
5CP4114CSS	3.2	12.1	4000	276	1750	20 mm
3CP1140	3.6	13.7	2200	152	1725	16.5 mm
5CP3110CSS	3.6	13.7	3500	241	1750	20 mm
760	3.6	13.7	5000	345	1750	24 mm
5CP4116CSS	3.8	14.4	4000	276	1750	20 mm
310	4.0	15.2	2200	152	950	20 mm
5CP2120W	4.0	15.2	2500	172	950	20 mm
5CP2140WCS	4.0	15.2	2500	172	1725	20 mm
3CP1120	4.2	16.0	2200	152	1725	16.5 mm
5CP4118CSS	4.2	16.0	4000	276	1750	20 mm
5CP3160CSS	4.3	16.3	3500	241	1750	20 mm
5CP3120CSS	4.5	17.0	3500	241	1645	20 mm
57	4.5	17.0	4000	276	1285	24 mm
5CP4120CSS	4.5	17.0	4000	276	1750	20 mm
60	4.7	17.9	4000	276	1750	24 mm
700	4.7	17.9	5000	345	1750	24 mm
5CP3120CSS	4.8	18.2	3000	207	1750	20 mm
310	5.0	19.0	1500	103	1190	20 mm
5CP2150W	5.0	19.0	2000	138	1725	20 mm
530	5.0	19.0	2500	172	1100	24 mm
5CP5120	5.0	19.0	3000	207	1415	20 mm
5CP3150CSS	5.2	19.7	3000	207	1750	20 mm
56	5.5	20.9	3500	241	1210	24 mm
5CP5140CSS	5.5	20.9	3500	241	1500	20 mm

\*\* 17 - 4SS Stainless Manifolds

$$\text{Electric Brake Hp} = \frac{\text{gpm} \times \text{psi}}{1460}$$

### Selecting a Power Source

Positive displacement pumps can use a variety of different power sources, including electric motors, gas or diesel engines, hydraulic and pneumatic motors. Note: system power sources must be sized with adequate horsepower to handle the maximum system flow and pressure required.

#### Commonly Used Formulas

$$\text{Required Electric Brake HP}^* = \frac{\text{gpm} \times \text{psi}}{1460}$$

$$\text{Hydraulic Torque (ft. lbs.) Required} = 3.6 \times \frac{\text{gpm} \times \text{psi}}{\text{rpm}}$$

\*Standard 85% Overall Efficiency

# Plunger Pumps

## SOLID SHAFT, BRASS MANIFOLD

PUMP MODEL	MAXIMUM FLOW		MAXIMUM PRESSURE		RPM	SHAFT
	GPM	LPM	PSI	BAR		
5CP6120	6.0	22.8	1600	110	1400	20 mm
5CP5120	6.0	22.8	2500	172	1750	20 mm
5CP5135CSS	6.0	22.8	3500	241	1750	20 mm
1570	6.0	22.8	6000	414	1350	30 mm
5CP5140CSS	6.4	24.3	3000	207	1750	20 mm
5CP6180CSS	6.9	26.1	1500	103	1450	20 mm
650	7.0	26.6	3000	207	1000	30 mm
5CP6120	7.4	28.1	1200	83	1725	20 mm
5CP6190	8.0	30.4	1450	100	1450	20 mm
56	8.0	30.4	2500	172	1760	24 mm
56HS	8.0	30.4	3000	207	1760	24 mm
5CP6180CSS	8.2	31.0	1500	103	1750	20 mm
1560	9.0	34.0	4000	276	1280	30 mm
5CP6190	10.0	38.0	1200	83	1750	20 mm
1050	10.0	38.0	2200	152	958	30 mm
660	10.0	38.0	3000	207	1429	30 mm
3550	10.0	38.0	6000	414	940	35 mm
6810**	10.0	38.0	10000	689	600	45 mm
7CP6110CS	10.5	39.9	2000	138	1725	24 mm
7CP6160CS	10.6	40.1	2500	172	1750	24 mm
7CP6170	11.0	41.6	2000	138	1450	24 mm
1050	12.0	45.4	1800	124	1150	30 mm
7CP6170	12.0	45.4	1800	124	1600	24 mm
1580	12.0	45.4	3000	207	1180	30 mm
1530	15.6	59.3	1500	103	1450	30 mm
1540E	18.0	68.4	1200	83	1100	30 mm
2510	20.0	76.0	2000	138	1450	30 mm
3560	20.0	76.0	4000	276	1160	35 mm
2530	25.0	95.0	1200	83	1025	30 mm
3520	25.0	95.0	2000	138	870	35 mm
3560	25.0	95.0	3000	207	1450	35 mm
3570*	30.0	113.6	3000	207	1080	35 mm
3535	36.0	136.2	1200	83	800	35 mm
3535HS*	40.0	152.0	2000	138	888	35 mm
6835	40.0	152.0	3000	207	625	45 mm
3545	45.0	171.0	1000	69	765	35 mm
3545HS*	50.0	189.3	1500	103	850	35 mm
67070	50.0	189.3	2000	138	653	45 mm
6760	60.0	228.0	1200	83	520	45 mm
67070*	65.0	246.0	2000	138	850	45 mm
6775	75.0	285.0	1200	83	650	45 mm

\* Intermittent duty only – operating pump at stated flow and pressure for no more than 50% of time in any given hour.

\*\* 304 Stainless Manifolds

$$\text{Electric Brake Hp} = \frac{\text{gpm} \times \text{psi}}{1460}$$

### Selecting a Drive

A variety of different drive options are offered by Cat Pumps. Most systems are belt-driven by a pulley or clutch, but there are also direct-drive options such as direct coupled, gearbox or hollow shaft direct drive.

#### Commonly Used Formulas

$$\text{Desired rpm} = \text{Desired gpm} \times \frac{\text{Rated rpm}}{\text{Rated gpm}} \quad \text{Pump Pulley}^* \times \frac{\text{Pump rpm}}{\text{Motor/Engine rpm}} = \text{Motor Pulley}^*$$

\*Pitch Diameter

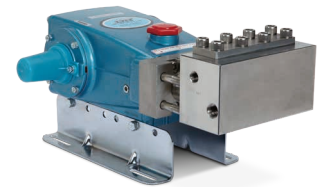

Model 1570

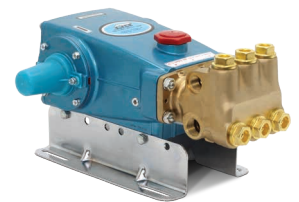

Model 660



Model 1540E

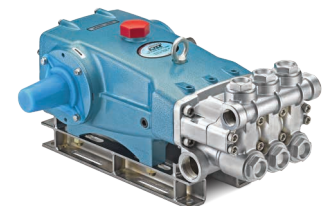

Model 3535

# Plunger Pumps

## SOLID SHAFT, 316 STAINLESS STEEL MANIFOLD



Model 311



Model 1051



Model 2531

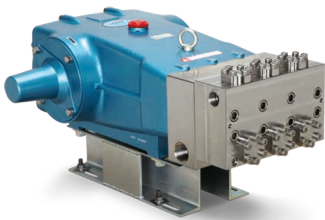

Model 6811

PUMP MODEL	MAXIMUM FLOW		MAXIMUM PRESSURE		RPM	SHAFT
	GPM	LPM	PSI	BAR		
3CP1231	2.3	8.7	2000	138	1725	16.5 mm
784	2.9	11.0	5000	345	1750	24 mm
3CP1241	3.6	13.7	2000	138	1725	16.5 mm
786	3.6	13.7	5000	345	1750	24 mm
341	4.0	15.2	1800	124	1725	20 mm
5CPQ6241CS	4.0	15.2	2000	138	1725	20 mm
311	4.0	15.2	2200	152	950	20 mm
3CP1221	4.2	16.0	2000	138	1725	16.5 mm
781	4.7	17.9	5000	345	1750	24 mm
351	5.0	19.0	1500	103	1725	20 mm
3CP1211CS	5.0	19.0	1700	117	1750	16.5 mm
5CPQ6251	5.0	19.0	2000	138	1725	20 mm
5CPQ6221	6.0	22.8	2000	138	1400	20 mm
5CPQ6221	7.4	28.0	1200	83	1725	20 mm
1051	10.0	38.0	2200	152	958	30 mm
3501	10.0	38.0	5000	345	915	35 mm
7CP6111CS	10.5	39.9	2000	138	1725	24 mm
7CP6171CS	10.5	39.9	2000	138	1450	24 mm
1051	12.0	45.4	1800	124	1150	30 mm
3511	14.0	53.2	3000	207	800	35 mm
6811	15.0	57.0	5000	345	600	45 mm
6801	15.0	57.0	7000	483	600	45 mm
1531	15.6	59.0	1500	103	1450	30 mm
1541	18.0	68.4	1200	83	1100	30 mm
2511	20.0	76.0	1500	103	1450	30 mm
2531	25.0	95.0	1200	83	1025	30 mm
3521DHS	25.0	95.0	2000	138	870	35 mm
6821	25.0	95.0	3000	207	615	45 mm
3531D	36.0	136.2	1200	83	800	35 mm
3531DHS*	40.0	152.0	2000	138	888	35 mm
6831	40.0	152.0	2300	159	625	45 mm
3541D	45.0	171.0	1000	69	765	35 mm
6841	48.0	182.4	2000	138	615	45 mm
3541DHS*	50.0	189.3	1500	103	850	35 mm
6761	60.0	228.0	1200	83	520	45 mm

\* Intermittent duty only – operating pump at stated flow and pressure for no more than 50% of time in any given hour.

$$\text{Electric Brake Hp} = \frac{\text{gpm} \times \text{psi}}{1460}$$



# Plunger Pumps

## SOLID SHAFT, DUPLEX STAINLESS STEEL MANIFOLD

PUMP MODEL	MAXIMUM FLOW		MAXIMUM PRESSURE		RPM	SHAFT
	GPM	LPM	PSI	BAR		
1051D	10.0	38.0	2200	152	958	30 mm
661D	10.0	38.0	3000	207	1429	30 mm
1051D	12.0	45.4	1800	124	1150	30 mm
6762	60.0	228.0	1200	83	520	45 mm
67102	80.0	302.8	1200	83	540	45 mm
67102	100.0	378.5	1000	69	680	45 mm
157R060	100.0	380.0	2700	186	310	100 mm
152R060	115.0	437.0	1200	83	360	100 mm
152R061	115.0	437.0	2000	138	360	100 mm
152R080	200.0	760.0	1200	83	355	100 mm
152R081	200.0	760.0	1560	108	355	100 mm
152R100	240.0	912.0	1000	69	270	100 mm

$$\text{Electric Brake Hp} = \frac{\text{gpm} \times \text{psi}}{1460}$$



Model 6762



Model 152R100

## BELT DRIVE, SOLID SHAFT, NICKEL ALUMINUM BRONZE MANIFOLD

PUMP MODEL	MAXIMUM FLOW		MAXIMUM PRESSURE		RPM	SHAFT
	GPM	LPM	PSI	BAR		
237	2.3	8.7	1500	103	1725	16.5 mm
277	3.5	13.3	1500	103	1420	16.5 mm
247	3.6	13.7	1200	83	1725	16.5 mm
347	4.0	15.2	1800	124	1725	20 mm
317	4.0	15.2	2200	152	950	20 mm
277	4.2	16.0	1000	69	1725	16.5 mm
357	5.0	19.0	1500	103	1725	20 mm
1057	10.0	38.0	2200	152	958	30 mm
3507	10.0	38.0	5000	345	915	35 mm
1057	12.0	45.4	1800	124	1150	30 mm
3517	14.0	53.2	3000	207	800	35 mm
2537	25.0	95.0	1200	83	1025	30 mm
3527	25.0	95.0	2000	138	870	35 mm
3537	36.0	136.2	1200	83	800	35 mm
3537HS*	40.0	152.0	2000	138	888	35 mm
3547	45.0	171.0	1000	69	765	35 mm
6747	48.0	182.4	2000	138	615	45 mm
6767	60.0	228.0	1200	83	520	45 mm

\* Intermittent duty only – operating pump at stated flow and pressure for no more than 50% of time in any given hour.

$$\text{Electric Brake Hp} = \frac{\text{gpm} \times \text{psi}}{1460}$$



Model 277

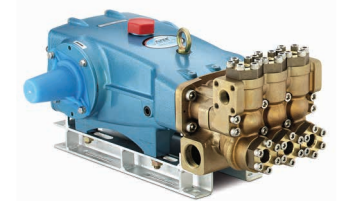

Model 3517

# Piston Pumps

## PISTON PUMPS, SOLID SHAFT, BRASS MANIFOLD

Belt Drive



Model 280

PUMP MODEL	MAXIMUM FLOW		MAXIMUM PRESSURE		RPM	SHAFT
	GPM	LPM	PSI	BAR		
280	3.0	11.4	1000	69	1330	16.5 mm
290	3.5	13.3	1200	83	1200	16.5 mm
333	4.0	15.2	1200	83	1070	16.5 mm
430	5.0	19.0	1000	69	1040	16.5 mm
323	5.0	19.0	1500	103	1000	20 mm
623	6.0	22.8	1200	83	850	25 mm
820	10.0	38.0	1000	69	940	25 mm
390	12.0	45.4	600	41	1200	20 mm
1010	13.0	49.4	700	48	900	25 mm
2520*	25.0	95.0	800	55	772	30 mm
6040	40.0	152.0	1500	103	500	45 mm
6020	60.0	228.0	1000	69	500	45 mm

\*Available as a model 2520C with flushed inlet manifold

$$\text{Electric Brake Hp} = \frac{\text{gpm} \times \text{psi}}{1460}$$



Model 820

## PISTON PUMPS, SOLID SHAFT, 316 STAINLESS STEEL MANIFOLD

Belt Drive

PUMP MODEL	MAXIMUM FLOW		MAXIMUM PRESSURE		RPM	SHAFT
	GPM	LPM	PSI	BAR		
281	3.0	11.4	1000	69	1330	16.5 mm
291	3.5	13.3	1200	83	1200	16.5 mm
331	4.0	15.2	1200	83	1070	16.5 mm
431	5.0	19.0	1000	69	1040	16.5 mm
621	6.0	22.8	1200	83	850	25 mm
821	10.0	38.0	1000	69	940	25 mm
1011	13.0	49.4	700	48	900	25 mm
6041	40.0	152.0	1500	103	500	45 mm
6021	60.0	228.0	1000	69	500	45 mm

$$\text{Electric Brake Hp} = \frac{\text{gpm} \times \text{psi}}{1460}$$



Model 2520



Model 6020

## TECH TIP

### Pump Rotation

Forward rotation (towards the manifold) is recommended to allow optimum lubrication of the crosshead area. If your installation does not allow for forward rotation, reverse rotation is acceptable if the crankcase oil is above the red dot in the oil gauge. This indicates adequate lubrication.



Forward Rotation



Reverse Rotation

# Flushed Manifold Pumps

## FLUSHED MANIFOLD PUMPS, SOLID SHAFT, BRASS, NICKEL ALUMINUM BRONZE Belt Drive

PUMP MODEL	MAXIMUM FLOW		MAXIMUM PRESSURE		RPM	SHAFT
	GPM	LPM	PSI	BAR		
1810K**	3.0	11.4	10000	689	1500	30 mm
1530C	15.6	59.0	1500	103	1450	30 mm
1540EC	18.0	68.4	1200	83	1100	30 mm
2520C	25.0	95.0	800	55	772	30 mm
3520C	25.0	95.0	2000	138	870	35 mm
3570C	30.0	114.0	3000	207	1080	30 mm
3535C	36.0	136.2	1200	83	800	35 mm

Model numbers ending in " C " indicate flushed cast manifold and " K " indicate flushed block manifold.

\*\*17 - 4SS Stainless Steel Manifolds

$$\text{Electric Brake Hp} = \frac{\text{gpm} \times \text{psi}}{1460}$$

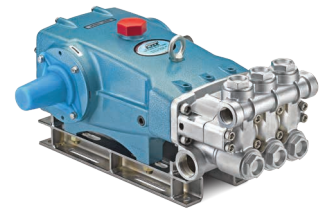

Model 3520C

## FLUSHED MANIFOLD PUMPS, SOLID SHAFT, 316 STAINLESS STEEL MANIFOLD Belt Drive

PUMP MODEL	MAXIMUM FLOW		MAXIMUM PRESSURE		RPM	SHAFT
	GPM	LPM	PSI	BAR		
341C	4.0	15.2	1800	124	1725	20 mm
311C	4.0	15.2	2200	152	950	20 mm
781K	4.7	17.9	5000	345	1750	24 mm
351C	5.0	19.0	1500	103	1725	20 mm
1051C	10.0	38.0	2200	152	958	30 mm
661C	10.0	38.0	3000	207	1429	30 mm
3501C	10.0	38.0	5000	345	915	35 mm
7CP6171CCS	10.5	39.9	2000	138	1450	24 mm
7CP6111CCS	10.5	39.9	2000	138	1750	24 mm
1051C	12.0	45.4	1800	124	1150	30 mm
3511C	14.0	53.2	3000	207	800	35 mm
6811K	15.0	57.0	5000	345	600	45 mm
6801K	15.0	57.0	7000	483	600	45 mm
1541C	18.0	68.0	1200	83	1100	30 mm
2531C	25.0	95.0	1200	83	1025	30 mm
3521C	25.0	95.0	2000	138	870	35 mm
6821K	25.0	95.0	3000	207	615	45 mm
3531C	36.0	136.2	1200	83	800	35 mm
6831K	40.0	152.0	2300	159	625	45 mm
3541C	45.0	171.0	1000	69	765	35 mm
6841K	48.0	182.4	2000	138	615	45 mm
6861K	60.0	228.0	1200	83	520	45 mm
67102C	100.0	378.5	1000	69	680	45 mm

Model numbers ending in " C " indicate flushed cast manifold and " K " indicate flushed block manifold.

$$\text{Electric Brake Hp} = \frac{\text{gpm} \times \text{psi}}{1460}$$

## FLUSHED MANIFOLD PUMPS, SOLID SHAFT, DUPLEX STAINLESS STEEL MANIFOLD Belt Drive

PUMP MODEL	MAXIMUM FLOW		MAXIMUM PRESSURE		RPM	SHAFT
	GPM	LPM	PSI	BAR		
152R060C	115.0	437.0	1200	83	360	100 mm
152R080C	200.0	760.0	1200	83	355	100 mm
152R100C	240.0	912.0	1000	69	270	100 mm

Model numbers ending in " C " indicate flushed cast manifold and " K " indicate flushed block manifold.

$$\text{Electric Brake Hp} = \frac{\text{gpm} \times \text{psi}}{1460}$$



Model 781K

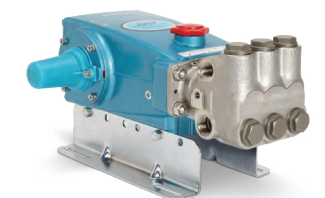

Model 1051C



Model 67102

# High Temperature Pumps

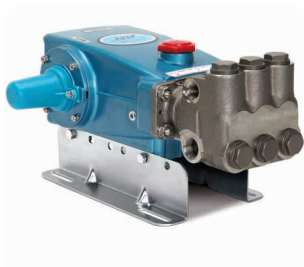

Model 1051.3400

## .3400 SERIES, HIGH-TEMPERATURE AND INTERMITTENT RUN DRY

The “.3400” Series pumps feature specially blended seals and V-packings, expanding pump operating performance to 190° F / 88° C. This modification also allows the pump to run intermittently dry without damaging the seals. Standard plunger pumps can be fitted with these specially blended seals. Ordering this configuration requires adding .3400 to pump base model. For example, a 310 pump fitted with high temperature seals will be 310.3400. Contact Cat Pumps for additional information.

# Triethylene Glycol (TEG) Pumps, 240° F



Model 3CP1120.44101

## HIGH-TEMPERATURE/TEG PUMPS, SOLID SHAFT, BRASS MANIFOLD

Belt and Bell Housing Drive

PUMP MODEL	MAXIMUM FLOW		MAXIMUM PRESSURE		RPM	SHAFT
	GPM	LPM	PSI	BAR		
3CP1130.44101	2.4	9.1	2200	152	1725	16.5 mm
5CP3105CS.44101	2.5	9.5	3500	241	1750	20 mm
3CP1140.44101	3.6	13.7	2200	152	1725	16.5 mm
5CP2120W.44101	4.0	15.2	2500	172	950	20 mm
5CP2140CS.44101	4.0	15.2	2500	172	1725	20 mm
3CP1120.44101	4.2	16.0	2200	152	1725	16.5 mm
5CP2150W.44101	5.0	19.0	2000	138	1725	20 mm
5CP6120.44101	6.0	22.8	1600	110	1400	20 mm
5CP6120.44101	7.4	28.0	1200	83	1725	20 mm
1050.44101	10.0	38.0	2200	152	958	30 mm
1050.44101	12.0	45.4	1800	124	1150	30 mm
1530.44101	15.6	59.0	1500	103	1450	30 mm
1540E.44101	18.0	68.4	1200	83	1100	30 mm
2530.44101	25.0	95.0	1200	83	1025	30 mm
3535.44101	36.0	136.0	1200	83	800	35 mm

$$\text{Electric Brake Hp} = \frac{\text{gpm} \times \text{psi}}{1460}$$

## HIGH-TEMPERATURE/TEG PUMPS, SOLID SHAFT, 316 STAINLESS STEEL AND NICKEL ALUMINUM BRONZE MANIFOLD

Belt and Bell Housing Drive

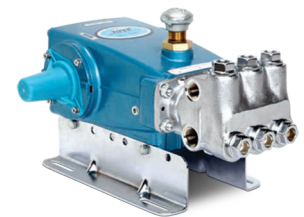

Model 1050.44101

PUMP MODEL	MAXIMUM FLOW		MAXIMUM PRESSURE		RPM	SHAFT
	GPM	LPM	PSI	BAR		
3CP1231.44101	2.3	8.7	2000	138	1725	16.5 mm
3CP1241.44101	3.6	13.7	2000	138	1725	16.5 mm
5CPQ6241.44101	4.0	15.2	2000	138	1725	20 mm
3CP1221.44101	4.2	16.0	2000	138	1725	16.5 mm
5CPQ6251.44101	5.0	19.0	2000	138	1725	20 mm
5CPQ6221.44101	6.0	22.8	2000	138	1400	20 mm
1051.44101	10.0	38.0	2200	152	958	30 mm
1051.44101	12.0	45.4	1800	124	1150	30 mm
3517.44101*	14.0	53.0	3000	207	800	35 mm
1531.44101	15.6	59.0	1500	103	1450	30 mm
1541.44101	18.0	68.4	1200	83	1100	30 mm
3521DHS.44101	25.0	95.0	2000	138	870	35 mm
2531.44101	25.0	95.0	1200	83	1025	30 mm
3531D.44101	36.0	136.2	1200	83	800	35 mm

\*Nickel Aluminum Bronze Manifold

$$\text{Electric Brake Hp} = \frac{\text{gpm} \times \text{psi}}{1460}$$



# Washout Resistant Pumps

## B SERIES, SOLID SHAFT, SPECIAL BRASS MANIFOLD, VEHICLE WASH Belt and Bell Housing Drive

PUMP MODEL	MAXIMUM FLOW		MAXIMUM PRESSURE		RPM	SHAFT
	GPM	LPM	PSI	BAR		
340B	4.0	15.2	1800	124	1725	20 mm
310B, 310BQ*	4.0	15.2	2200	152	950	20 mm
5CP2120B	4.0	15.2	2500	172	950	20 mm
5CP2140BCS	4.0	15.2	2500	172	1725	20 mm
350B	5.0	19.0	1500	103	1725	20 mm
5CP2150B	5.0	19.0	2000	138	1725	20 mm

\*"Q" Option is designed for applications where a reduced sound level is desirable.

$$\text{Electric Brake Hp} = \frac{\text{gpm} \times \text{psi}}{1460}$$



Model 310B

# Liquid CO<sub>2</sub> Pumps

Cat Pumps liquid CO<sub>2</sub> series of pumps feature modifications to accommodate the unique properties of liquid CO<sub>2</sub>. Specialty seals are used to handle low lubricity and low temperature that liquid CO<sub>2</sub> applications require. Pump manifolds are modified to allow higher inlet pressures and discharge pressures up to 7,000 psi (483 bar). Drive-end and manifold material combinations are available to cover a wide flow range of flow from 0.34 to 50 gpm (1.3 to 189.2 lpm).

Cat Pumps offers full technical and engineering support to properly select pumps for the specific application. Pumps are available in brass and 316 stainless steel. Cat Pumps has provided liquid CO<sub>2</sub> pumping solutions for over 25 years, working closely with research facilities, universities, equipment manufacturers and site locations to design and provide the best solutions. Please contact Cat Pumps for additional information.



Model 1530RSCM.CO2

# Demand Genuine Cat Pumps Accessories

## MAXIMUM SYSTEM PERFORMANCE

Cat Pumps offers a wide range of high quality accessories adhering to the same exacting standards as our industry-leading pumps. Every accessory is performance tested and designed to match each pump's operating specifications. By demanding genuine Cat Pumps products, you receive the best value and lowest cost of ownership over the life of the system. Protect your pumping system investment with the brand you can trust — Cat Pumps.



# ATEX Pumps

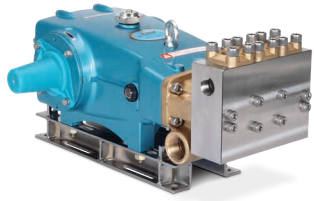

3560 ATEX

Under the ATEX Directive, equipment is designated by group, category and zone. Cat Pumps has been certified as ATEX 2, which also covers ATEX 3 requirements.

ATEX-certified high-pressure pumps will be specially labeled and supplied with a signed ATEX Declaration of Conformity. Pumps will be numbered with the “.ATEX2” suffix added to the standard pump model number. Contact Cat Pumps for additional information.

The following pump series comply with the ATEX directive for Group 2, Category 2, and Zones 1 and 2. This Group 2 includes Zones G [1 & 2]

## Pump Series

- 3CP\* Plunger Pumps
- 3 Frame\* Plunger Pumps
- 5CP\* Plunger Pumps
- 5 Frame\* Plunger Pumps
- 7CP\* Plunger Pumps
- 7 Frame\* Plunger Pumps
- 8 Frame Plunger Pumps
- 15 Frame Plunger Pumps
- 18 Frame Plunger Pumps
- 25 Frame Plunger Pumps
- 28 Frame Plunger Pumps
- 35 Frame Plunger Pumps
- 38 Frame Plunger Pumps
- 60 Frame Plunger Pumps
- 68 Frame Plunger Pumps

\* Excludes models equipped with gearbox

# 1CX Series Compact Misting Pumps



## MODEL NUMBER SELECTION CHART

Pump with Electric Motor, 1000 psi max pressure

SERIES	FLOW (1750 RPM)	REGULATOR	ASSEMBLE OPTION	MOTOR OPTION*	PULSE HOSE OPTION
1CX	013 = .13 gpm	R = Regulator Included	D = Pump and motor shipped together – not assembled	1 = 8180	Blank = No Pulse Hose
	025 = .25 gpm			2 = 8182	
	050 = .5 gpm		A = Pump and motor assembled together	3 = 8185	P = Pulse Hose Included
		4 = 8183			
				5 = 8186	

**Example:** 1CX050RA2P = .5 gpm, Regulator, 8182 Motor, Assembled, Pulse Hose included

### \*Motor Options:

- |  |   |
|--|---|
| 1. 8180 – ¼ hp, ODP, 115/230 V, 60Hz, 1ph, 1750 rpm, 12 inch leads | 4. 8183 – ½ hp, ODP, 115/230 V, 50Hz, 1ph, 1450 rpm, terminal box   |
| 2. 8182 – ½ hp, ODP, 115/230 V, 60Hz, 1ph, 1750 rpm, 12 inch leads | 5. 8186 – ½ hp, TEFC, 115/230 V, 60 Hz, 1ph, 1750 rpm, terminal box |
| 3. 8185 – ½ hp, ODP, 115/230 V, 60Hz, 1ph, 1750 rpm, terminal box  |   |

\* NOTE: Without pulse hose amp draw will increase as much as 2 amps depending upon pump model and discharge pressure.

\*\* HP Calculation (1CX Series only): GPM x PSI ÷ 1060

# 1XP Series Portable Extractor Pumps

## 1XP Pump with AC Induction Motor

- Long Service Life
- Dual Frequency for world-wide use
- Constant torque



### AC Induction Motor – 60 Hz, 120V (1750 rpm)

GPM	MAX PSI	PUMP ASSEMBLY	SFA	HP
0.5	600	1XP050.031		
0.75	500	1XP075.031		
0.85	500	1XP085.031		
1	450	1XP100.031	4.0	1/3
1.25	400	1XP125.031		
1.5	325	1XP150.031		
2	250	1XP200.031		
0.4	1000	1XP050.051		
0.7	1000	1XP075.051		
0.8	1000	1XP085.051		
0.9	800	1XP100.051	8.0	1/2
1.2	800	1XP125.051		
1.5	600	1XP150.051		
2	450	1XP200.051		
0.9	1000	1XP100.071		
1.1	1000	1XP125.071		
1.4	800	1XP150.071	9.0	3/4
1.75	700	1XP180.071		
2	550	1XP200.071		
1.45	1000	1XP150.101		
1.8	800	1XP180.101	12.6	1
2	750	1XP200.101		

### AC Induction Motor – 50 Hz, 240V (1450 rpm)

GPM	MAX PSI	PUMP ASSEMBLY	SFA	HP
0.40	600	1XP050.031		
0.60	500	1XP075.031		
0.70	500	1XP085.031		
0.80	450	1XP100.031	2.1	1/3
1	400	1XP125.031		
1.2	325	1XP150.031		
1.70	250	1XP200.031		
0.30	1000	1XP050.051		
0.60	1000	1XP075.051		
0.70	1000	1XP085.051		
0.75	800	1XP100.051	3.8	1/2
1	800	1XP125.051		
1.2	600	1XP150.051		
1.70	450	1XP200.051		
0.75	1000	1XP100.071		
0.90	1000	1XP125.071		
1.20	800	1XP150.071	4.6	3/4
1.50	700	1XP180.071		
1.70	550	1XP200.071		
1.20	1000	1XP150.101		
1.40	800	1XP180.101	6.3	1
1.70	750	1XP200.101		

## 1XP Pump with DC Permanent Magnet Motor

- Low amp draw
- Compact
- Lighter weight



### DC Permanent Magnet – 120 Volt - 1/3 HP ODP and TEFC Enclosures

GPM	MAX PSI	AMPS (AT MAX PSI)	PUMP ASSEMBLY ODP MOTOR	PUMP ASSEMBLY TEFC MOTOR
0.5	600	4.0	1XP050.03DC	1XP050.03DCT
0.75	500	4.0	1XP075.03DC	1XP075.03DCT
0.85	400	4.0	1XP085.03DC	1XP085.03DCT
1	350	4.0	1XP100.03DC	1XP100.03DCT
1.25	300	4.0	1XP125.03DC	1XP125.03DCT
1.5	250	4.0	1XP150.03DC	1XP150.03DCT
2.3	150	4.0	1XP200.03DC	1XP200.03DCT

### DC Permanent Magnet – 240 Volt - 1/3 HP ODP

GPM	MAX PSI	AMPS (AT MAX PSI)	PUMP ASSEMBLY ODP MOTOR
0.5	600	2.0	1XP050.03DC2
0.75	500	2.0	1XP075.03DC2
0.85	400	2.0	1XP085.03DC2
1	350	2.0	1XP100.03DC2
1.25	300	2.0	1XP125.03DC2
1.5	250	2.0	1XP150.03DC2
2.3	150	2.0	1XP200.03DC2

# Centrifugal Pumps



## 1K SERIES – SUBMERSIBLE SUMP PUMPS

Stainless steel submersible sump pumps offer solutions to pumping semi-dirty water or fresh water with suspended solids up to 3/8".

Flow Range	Up to 88 gpm	Operation	Manual or Automatic
Pressure Range (up to 24 psi)	55 ft. Head	Maximum Temperature	Continuous 122°F
RPM	3450 rpm		Intermittent 140°F
Discharge Fitting	1 1/4", 1 1/2" NPT(F)	Maximum Solids Diameter	3/4"
Horsepower	1/3, 1/2, 3/4, 1, 1 1/2 HP		



## 2K SERIES – SUBMERSIBLE PUMPS

Stainless steel submersible pumps offer reliable pumping of freshwater or industrial waste water with suspended solids up to 2".

Flow Range	Up to 180 gpm	Operation	Manual or Automatic
Pressure Range (up to 19.5 psi)	46 ft. Head	Maximum Temperature	Continuous 104°F
RPM	3450 rpm		Intermittent 140°F
Discharge Fitting	2" NPT(F)	Maximum Solids Diameter	2"
Horsepower	1/2, 1, 1 1/2, 2 HP		



## 3K SERIES – END-SUCTION CENTRIFUGAL PUMPS, SINGLE STAGE

Stainless steel end-suction centrifugal pumps offer dependable performance and flexibility in moving high volume liquids at low pressure. Single stage sold as either pump kit or motorized unit.

Flow Range	Up to 90 gpm	Discharge Fitting	1" NPT(F)
Pressure Range (up to 63 psi)	145 ft. Head	Shaft Seal	Mech Type 21
Minimum Inlet Pressure to Prime	Flooded	Horsepower	1/3, 1/2, 3/4, 1, 1 1/2, 2, 3 HP
RPM	1725 or 3450 rpm	Maximum Temperature	160°F
Inlet Fitting	1 1/4", 1 1/2" NPT(F)		



## 3K SERIES - END-SUCTION CENTRIFUGAL PUMPS, TWO STAGE (METRIC FRAME)

Stainless steel end-suction centrifugal pumps offer dependable performance and flexibility in moving high volume liquids at low pressure. Sold as motorized unit only.

Flow Range	Up to 66 gpm	Discharge Fitting	1" NPT(F)
Pressure Range (up to 106 psi)	245 ft. Head	Shaft Seal	Mech Type 21
Minimum Inlet Pressure to Prime	Flooded	Horsepower	2, 3, 5 (IP 55 TEFC)
RPM	3450 RPM	Maximum Temperature	140°F
Inlet Fitting	1 1/4", 1 1/2" NPT(F)		



## 3K SERIES - END-SUCTION CENTRIFUGAL PUMPS, TWO STAGE (NEMA FRAME)

Stainless steel end-suction centrifugal pumps offer dependable performance and flexibility in moving high volume liquids at low pressure. Sold as either pump kit or motorized unit.

Flow Range	Up to 66 gpm	Discharge Fitting	1" NPT(F)
Pressure Range (up to 106 psi)	245 ft. Head	Shaft Seal	Mech Type 21
Minimum Inlet Pressure to Prime	Flooded	Horsepower	2, 3, 5
RPM	3450 RPM	Maximum Temperature	140°F
Inlet Fitting	1 1/4", 1 1/2" NPT(F)		



# Centrifugal Pumps

## 4K SERIES – END-SUCTION CENTRIFUGAL PUMPS, SINGLE STAGE

Sold as pump kit or motorized unit.

Flow Range	Up to 380 gpm	Discharge Fitting Flange	ANSI 150 lb. – 1¼", 1½", 2"
Pressure Range (up to 124 psi)	286 ft. Head	Shaft Seal	Mech Type 21
Minimum Inlet Pressure to Prime	Flooded	Horsepower	1, 1 ½, 2, 3, 5, 7 ½, 10, 15 HP
RPM	1725 or 3450 rpm	Maximum Temperature	160°F
Inlet Fitting Flange	ANSI 150 lb. – 2", 2 ½", 3"		



## 5K SERIES – SELF PRIMING CENTRIFUGAL PUMPS

Sold as pump kit or motorized unit.

Flow Range	Up to 18.5 gpm	Discharge Fitting	1" NPT(F)
Pressure Range (up to 82 psi)	190 ft. Head	Shaft Seal	Mech Type 21
RPM	3450 rpm	Horsepower	1, 2 HP
Inlet Fitting	1 ¼" NPT(F)	Maximum Temperature	113°F



## 6K SERIES - OPEN IMPELLER END-SUCTION CENTRIFUGAL PUMPS

Stainless steel open impeller centrifugal pumps handles suspended solids in liquid and dirty water, and handles solids up to ¾" spherical. Sold as motorized unit only.

Flow Range	Up to 250 gpm	Discharge Fitting	2" NPT(F) (with external hose barb)
Pressure Range (up to 28 psi)	65 ft. Head	Shaft Seal	Mech Type 21
Minimum Inlet Pressure to Prime	Flooded	Horsepower	1 ½, 2, 3, 4
RPM	3450 RPM	Maximum Temperature	194°F
Inlet Fitting	2", 2 ½" NPT(F)		



## 8K SERIES - VERTICAL MULTIPLE STAGE CENTRIFUGAL PUMPS

Stainless steel vertical multiple stage pumps designed for high volume and high ft. head clean or hot water applications. Sold as a bare pump or motorized unit (w/NEMA motor sizes).

Flow Range	Up to 390 gpm	Discharge Fitting	1 ¼" to 4" ANSI
Pressure Range (up to 403 psi)	930 ft. Head	Shaft Seal	Mechanical - Silicon / Carbide / Carbon / FPM
Minimum Inlet Pressure to Prime	Flooded	Horsepower Range	½ to 50 HP
RPM	3450 RPM	Temperature Range	-22°F to 248°F
Inlet Fitting	1 ¼" to 4" ANSI		



# Custom Pumping Systems

YOU DEFINE. WE DESIGN AND DELIVER.

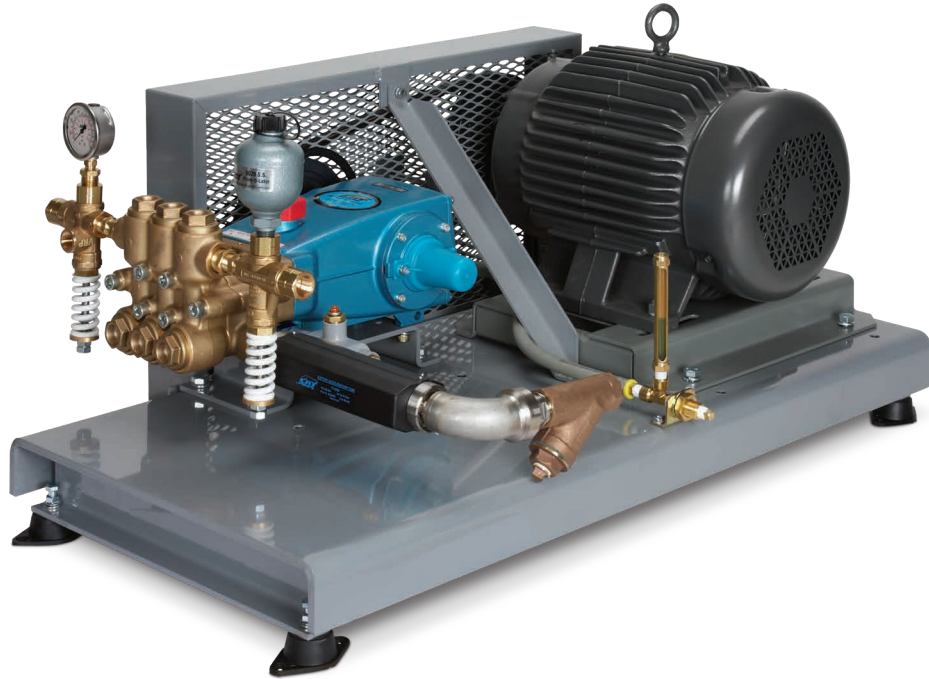

## Custom Engineered to Meet Your Application Demands



Cat Pumps is an industry leader in providing customers with quality custom-engineered pumping systems to meet a wide range of application needs. By selecting a Cat Pumps pumping system, customers eliminate the hassle and expense of designing, multiple source buying, fabricating and testing. Our knowledgeable and helpful technical sales team assists with proper component selection as well as installation, operation and maintenance support.

**Call or go online to start your quote today.**

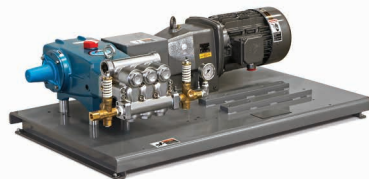

# Custom Pumping Systems

## System Configuration

With extensive experience building thousands of systems, Cat Pumps can help determine the best configuration for any application.

### Base

System design starts with choosing the base that best fits the application. Numerous base configurations are available to meet space, portability, sound and material demands.

- Standard • Vertically Stacked • Portable • Enclosed • Multiple Pump

### Power Source

A qualified technical staff with extensive experience can assist in recommending the correct product for any power source available.

- Electric • Gas • Diesel • Hydraulic • Pneumatic

### Drive Package

A wide variety of drive packages are available to complement any power source of choice.

- Belt • Direct Drive • Gearbox • Flex Coupling/Bell Housing • Clutch

### Accessories

Choose from hundreds of high-quality genuine Cat Pumps accessories for optimum system performance and life.

- Regulator • Unloader • Relief / Pop-off Valve • Pressure Gauge
- Pulsation Dampener • Inlet Stabilizer • Inlet Filter / Strainer • Guns • Oil

## Cat Pumps Advanced Control Options



Ask about the wide variety of advanced control options designed to provide maximum system performance as well as maximum system protection.

Options include:

- Variable Frequency Drives (VFD)
- PID Loop (varies speed of pump to maintain system pressure)
- Multiple Pump Systems
- Low-Pressure Seal Monitors
- Auto Shutdowns (Temperature and Low Inlet Pressure)

Other control options are available upon request.

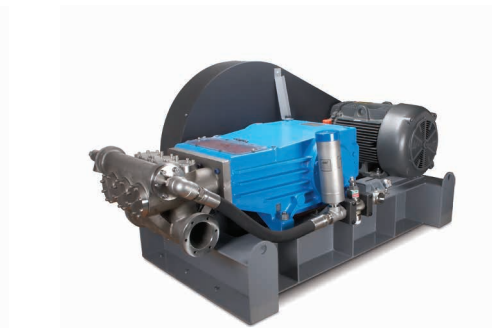



# PIJTTERSEN

Pijttersen B.V.  
Beneluxweg 33  
9636 HV Zuidbroek  
Tel.: +31(0)50-8200963

KvK 01013855  
BIC RABONL2U  
BTW NL002166811B01  
IBAN NL24 RABO 0353 2970 97



*The Pumps with Nine Lives*

[www.pijttersen.nl](http://www.pijttersen.nl) - [info@pijttersen.nl](mailto:info@pijttersen.nl) | [www.catpumps.nl](http://www.catpumps.nl) - [info@catpumps.nl](mailto:info@catpumps.nl)